



**TITLE: TENDER FOR PROVISION OF TOOLS**

**TENDER REFERENCE NUMBER: REMCO/FA/27/2025-2026**

**PROCURING ENTITY: RWANDA ENGINEERING AND  
MANUFACTURING CORPORATION (REMCO)**

**PROCUREMENT METHOD: OPEN INTERNATIONAL COMPETITIVE  
BIDDING**

**DATE OF ISSUE: 27<sup>th</sup> March 2026**

**DEADLINE OF SUBMISSION: 9<sup>th</sup> April 2026**

NE

## TERMS OF REFERENCE FOR TOOLS

### SECTION 1. INTRODUCTION AND BACK GROUND

Rwanda Engineering and Manufacturing Corporation (REMCO) is a company that started in 2018 and is owned by the government of Rwanda. REMCO was established to manufacture machines, equipment and spare parts that were previously imported to serve in the sectors of Agriculture mechanization, Construction, Mining, Automotive, Energy, Defense and Health care. REMCO also provides technical support services to other local as well as regional companies through training, repair and maintenance services.

REMCO has got a machine shop/ factory where manufacture and assemble of different product is carried out during these activities they need kind of different tools which are used in production of final product . It is in that regard that therefore REMCO would like to invite qualified bidders to submit their bids/offers for the tender for provision supply of tools .

### SECTION 2. SCOPE OF SERVICE

The successful bidder shall be required to provide **tools** . as per the required specification and requirements mentioned in this document below in the right quantities and best quality and they must be able to serve the purpose for which they are intended to.

The above services shall be offered at the successful bidder's premises and shall be rendered successful upon thorough and clear inspection by the appointed member of REMCO staff.

### SECTION 3. TENDER PRESENTATION AND REQUIREMENTS

All tenders must include and present the following phases and they will be evaluated in the same fashion.

#### 3.1. ADMINISTRATIVE ELIGIBILITY

All bidders shall provide the following documents as the first criteria to be followed for the first stage of evaluation.

- a. A valid business registration certificate
- b. A valid company profile



#### 3.2. TECHNICAL QUALIFICATION AND INSTRUCTIONS





All bidders shall present the following as the second criteria to be followed in the second stage of evaluation.





- a. A list of specifications that must correspond to the following specifications. lower specification will not be tolerated or accepted.



NE

ITEMS REQUIRED

Item No.	Items name	Item Description	Unit	quantity
1	Drill bits(Twist Drill)	 <p>HSS with Cobalt (HSS-Co)</p> <p>1mm,1.5 mm, 2 mm,3 mm,4 mm,5 mm 6mm ,8mm, 8.5mm,9mm,9.5mm,10mm,10.5mm ,11mm,12m m,13mm,14mm,15mm,15.5mm, 16mm,17.5mm,18mm, 18.5mm, 19.5mm, 20mm,..... up to 50mm</p>	set	10
2	Drill bits(Twist Drill)	 <p>Carbide drill bits</p> <p>1mm,1.5 mm, 2 mm,3 mm,4 mm,5 mm 6mm ,8mm,8.5mm,9mm,9.5mm,10mm,10.5mm , 11mm,12mm,13mm,14mm,15mm,15.5mm, 16mm,17.5mm,18mm, 18.5mm, 19.5mm, 20mm,..... up 50mm</p>	set	20
3	Drill bits(Brad Point Drill)	 <p>Carbide drill bits</p> <p>1mm,1.5 mm, 2 mm,3 mm,4 mm,5 mm 6mm ,8mm,8.5mm,9mm,9.5mm,10mm,10.5mm , 11mm,12mm,13mm,14mm,15mm,15.5mm, 16mm,17.5mm,18mm, 18.5mm, 19.5mm, 20mm,..... up 50mm</p>	set	20

4	Drill bits (Brad Point Drill)	 <p>HSS drill bits</p> <p>1mm, 1.5 mm, 2 mm, 3 mm, 4 mm, 5 mm 6mm, 8mm, 8.5mm, 9mm, 9.5mm, 10mm, 10.5mm, 11 mm, 12mm, 13mm, 14mm, 15mm, 15.5mm, 16mm, 17.5mm, 18mm, 18.5mm, 19.5mm, 20mm,..... up 50mm</p>	set	15
5	Drill chucks and sleeves for Drilling machine a	 <p>Reducing Drill Sleeve MT1 MT2 MT3 MT4 MT5 MT6 Morse</p> <p>Taper Sleeve Arbor Morse Taper Adapter Reducing Drill Sleeve</p>	set	3
6	Drill chucks	 <p>5-20mm Heavy Duty Drill Chuck with 2 pack</p>	set	10
7	Holding vise	 <p>5 Inch Milling Vise, Precision Mill Vise, Heavy Duty Milling Machine Vise Steel Jaw Material, Lockdown Clamping Vise ACCU Without Bas</p>	PC	5

8	universal vice	 <p>Horizontal rotary: range 360°, graduation 0.05° Vertical incline: range 45°, graduation 0.05° With incline adjust knob Made of tool steel Hardness HRC56-58 Jaw opening :200 mm</p>	PC	2
9	Flat endmill	 <p>Carbide Steel Diameter : 1mm, 1.5mm, 2mm, 2.5mm, 3mm, 4mm, 5mm, 6mm, 8mm, 10mm, 12mm, 14mm, 16mm and 20mm up to 50mm</p>	set	10
10	Ball end mill	 <p>Material: Carbide Diameter : 1mm, 1.5mm, 2mm, 2.5mm, 3mm, 4mm, 5mm, 6mm, 8mm, 10mm, 12mm, 14mm, 16mm, up to 50mm</p>	set	5
11	Wood rough cutter	 <p>HSS-AL, T Slot End Mill Milling Cutter High-Speed, Steel Woodruff Keyset Cutter, Half Round Keyway Milling Cutter, Straight Shank, 6 Flutes, 18 x 3 x 65mm</p>	set	5

12	Taps	 <p>HSS TAP, right hand: M6X1mm, M8X1.25, M8X1mm, M8X0.5 M8X0.8 M10X1.5, M10X1.25, M12X1, M12X1.25, M12X1.5mm and M12X1.75mm, M14X2mm, M14X1.5mm M14X1mm</p>	set	5
13	Gear puller	 <p>Gear Puller set, 3", 4", 6" Jaw Puller kit for pulley Gear Bearing Flywheel removal, Heavy Duty Pulley</p>	set	3
14	Insert	Turning inserts TNMG 160404	Box	10
15	Insert	Parting of tool insert IC 308	Box	10
16	Milling head	Milling head FME 02 -0800- A 27 SN09-09	Pcs	10
17	Milling Insert	Milling Insert SNEN0904	Pcs	500
18	Milling cutter	<p>HSS slitting saw blade milling cutter tools types : slitting saw milling cutter OD: 60mm ,thickness :2mm,bore dia:16mm,number of teeth: 48-60 teeth,dia tolerance <math>\pm 0.1</math>mm thickness tolerance <math>\pm 0.05</math>mm,speed 30-45m/min,suitable for mild steel ,aluminium,brass and plastics</p> 	Pc	

### 3.3. FINANCIAL PROPOSAL

All bidders shall present their financial offers and these shall be competitive and must spell value for money. This shall be third criteria to be followed in the third stage of evaluation.

The financial evaluation will be conducted according to prices offered for every items as they are presented on the table attached as annex here above.

- Every bidder shall provide a well signed and stamped financial offer.
- Every offer shall be presented in the Local currency which is Rwanda francs (RWF) and in united states dollars(USD). for foreign/international supplies.

#### SECTION 4. SUBMISSION OF OFFERS

- a. Offers must be submitted not later than 9<sup>th</sup> April 2026 at 23:59 Pm Local time, late offers will be rejected and will not be opened or considered.
- b. Offers must be submitted by email through [procurement@remco.rw](mailto:procurement@remco.rw). Any queries must be addressed to the CEO of REMCO and sent to the same email with [info@remco.rw](mailto:info@remco.rw) in copy.
- c. The language to be used as the medium of communication in all the offers shall be in English.
- d. This tender shall only be valid for Seven (7) days.

#### SECTION 5. OTHER TERMS AND CONDITIONS

- a. REMCO reserves the right to visit any bidder's location/premises during tender evaluation.
- b. All bids shall be opened and evaluated in the absentia of all bidders.
- c. REMCO reserves the right to reject any offer where, in its opinion, a conflict of interest exists or may arise such as influence of any kind, professional or financial relationships with employees.
- d. The payment terms shall be 100% payment by cheque or bank transfer upon agreed terms.

We are looking forward to receiving your great offers.

Sincerely



**Eric NYAMUHENDA**  
Acting Chief Executive Officer  
REMCO Ltd

REMCO

DEPARTMENT

**INTERNAL REQUISITION**



To: Ag CEO  
 Tel/Ext: 0782556005  
**Info:**  
 Your Ref:



From: Production team leader  
 Tel/Ext: 0789677389  
**Our Ref:**  
 Date: 09/10/2025  
 Requisition No: MS/10/05  
 Project/Activity Name: machining, drilling, tapping, assembly and holding.

*For review  
 9.10.2025  
 To procurement  
 handle this  
 accordingly*

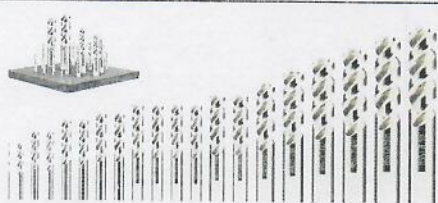



Purpose of the requisition: various tools are required daily to carry out routine operations.

**1. Item/Service required**

Item No.	Items name	Item Description	Unit	Qty	Required Delivery Date/time
1	Drill bits	 <p>HSS with Cobalt (HSS-Co)                      1mm,1.5 mm, 2 mm,3 mm,4 mm,5 mm 6mm ,8mm, 8.5mm,9mm,9.5mm,10mm,10.5mm ,11mm,12mm,13mm,14mm,15mm,15.5mm, 16mm,17.5mm,18mm, 18.5mm, 19.5mm, 20mm</p>	set	5	30/10/2025
2	Drill chucks and sleeves for Drilling machine a	 <p>DEDK -40CrMo Steel -HRC52                      MT1 MT2 MT3                      MT4 MT5 MT6</p> <p>Reducing Drill Sleeve MT1 MT2 MT3 MT4 MT5 MT6 Morse                      Taper Sleeve Arbor Morse Taper Adapter Reducing Drill Sleeve</p>	set	3	30/10/2025

3	Drill chucks	 <p>5-20mm Heavy Duty Drill Chuck with 2 pack</p>	set	10	30/10/2025
4	Holding vise	 <p>5 Inch Milling Vise, Precision Mill Vise, Heavy Duty Milling Machine Vise Steel Jaw Material, Lockdown Clamping Vise ACCU Without Bas</p>	PC	5	30/10/2025
5	universal vise	 <p>Horizontal rotary: range 360°, graduation 0.05° Vertical incline: range 45°, graduation 0.05° With incline adjust knob Made of tool steel Hardness HRC56-58 Jaw opening :200 mm</p>	PC	2	30/10/2025

*Handwritten signature*

6	Flat endmill	 <p>Carbide Steel Diameter :1mm, 1.5mm, 2mm, 2.5mm, 3mm, 4mm, 5mm, 6mm, 8mm, 10mm, 12mm, 14mm, 16mm and 20mm</p>	set	10	30/10/2025
7	Ball end mill	 <p>Material: Carbide Diameter :6mm, 8mm, 10mm and 12</p>	set	5	30/10/2025
8	Wood rough cutter	 <p>HSS-AL, T Slot End Mill Milling Cutter High-Speed, Steel Woodruff Keyset Cutter, Half Round Keyway Milling Cutter, Straight Shank, 6 Flutes, 18 x 3 x 65mm</p>	set	5	30/10/2025
9	Taps	 <p><b>M2-M16 Thread Taps Set</b> HSS TAP, right hand: M6X1mm, M8X1.25, M8X1mm, M8X0.5 M8X0.8 M10X1.5, M10X1.25, M12X1, M12X1.25, M12X1.5mm and M12X1.75mm, M14X2mm, M14X1.5mm M14X1mm</p>	set	5	30/10/2025

10	Gear puller	 <p data-bbox="414 504 1133 582">Gear Puller set, 3", 4", 6" Jaw Puller kit for pulley Gear Bearing Flywheel removal, Heavy Duty Pulley</p>	set	3	30/10/2025
----	-------------	--	-----	---	------------

**2. Justification/Additional notes:**

The specified various materials are required daily to carry out routine operations such as machining, drilling, tapping, assembly and holding.

**3. Budget Confirmation**

Field	Details
<b>Budget Line / Account No:</b>	
<b>Is budget available?</b>	
<b>Confirmed by:</b>	
<b>Date:</b>	

**4. Approval**

Name	Title	Signature	Date
Immediate Supervisor			
Department Head	Machine shop T. leader		09/10/2025
Finance Manager			
CEO			

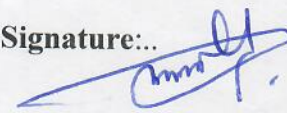
Names: ..... Appointment: Machine shop T. leader ..... Signature: 

Eng. Jean NKURIKIYIMANA

